

図5.4.A F3C コンテストエリア・レイアウト

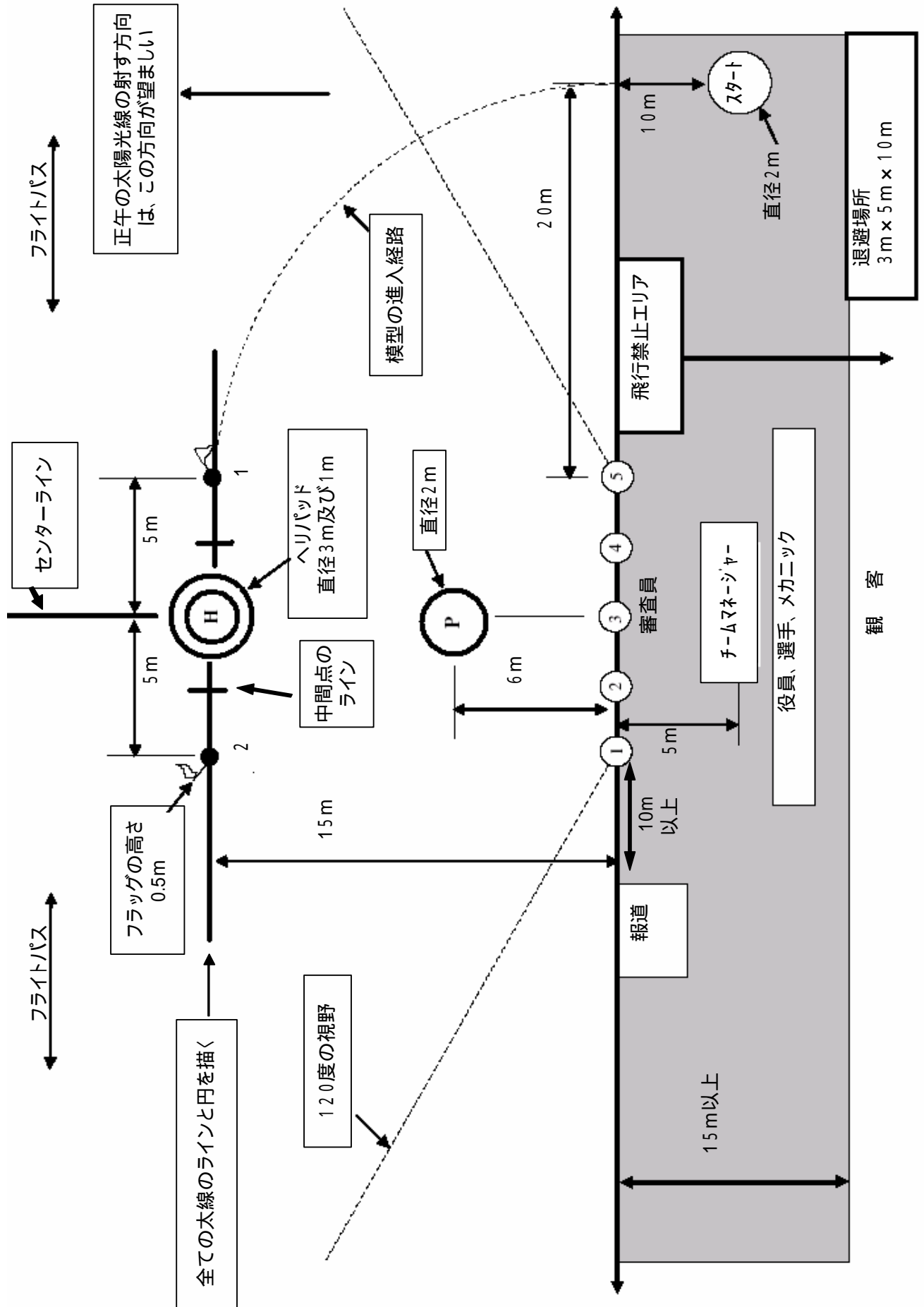

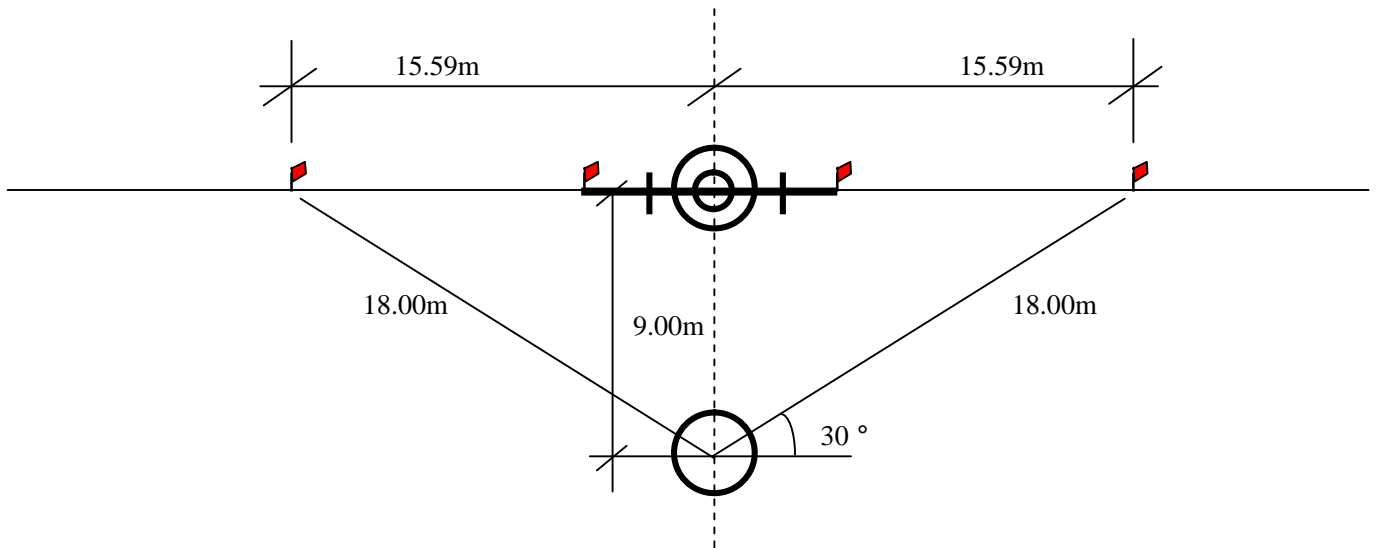

パイロット用フラッグ付き120°マーキング

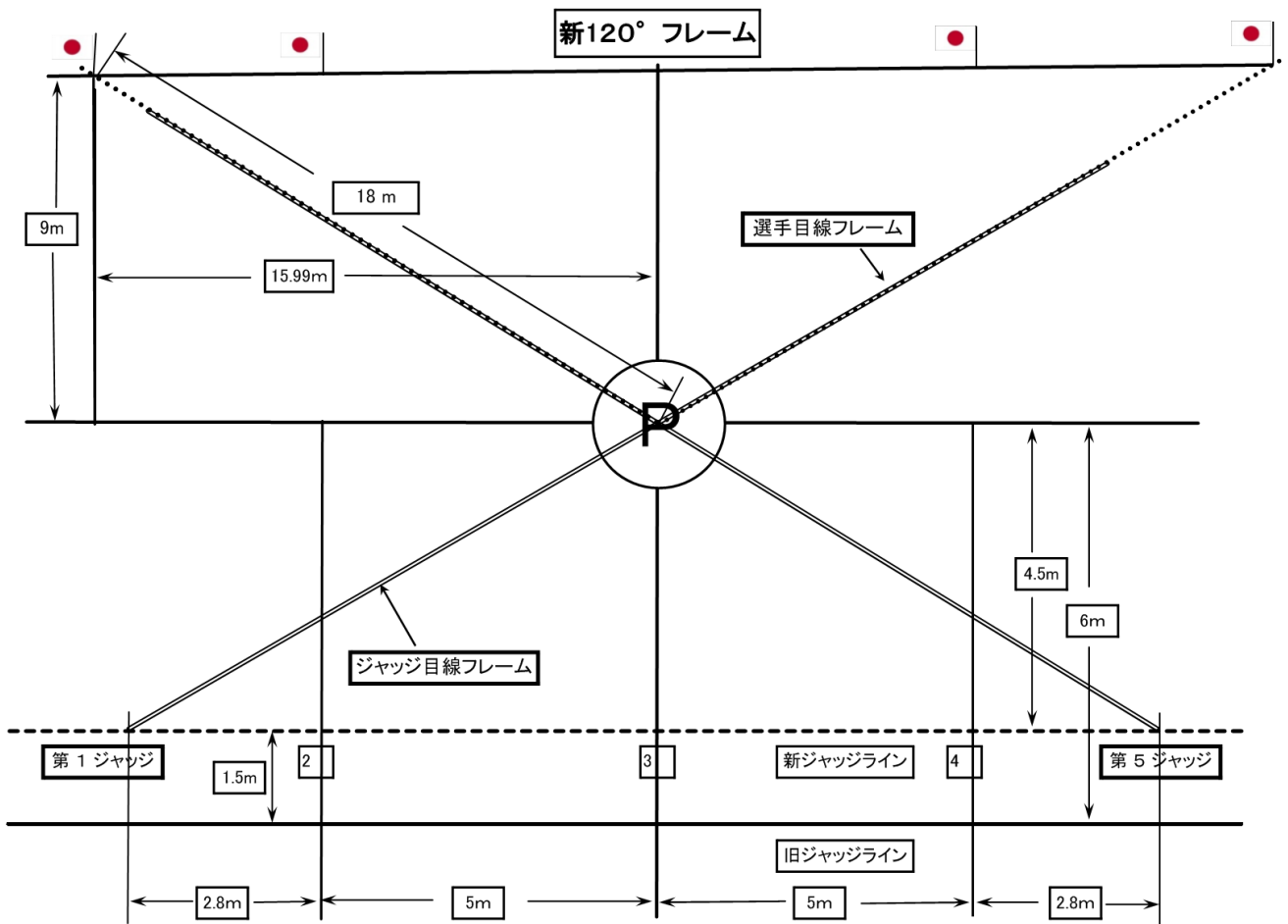

新120°フレーム用 ジャッジライン等の補足
(日本選手権で適用)

図 5 D - P F 3 C スケジュール・P

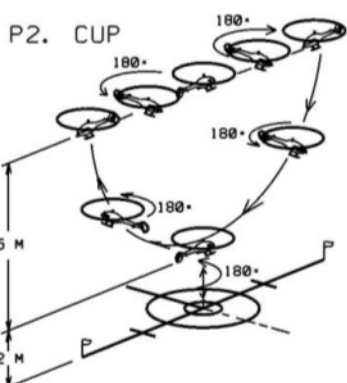
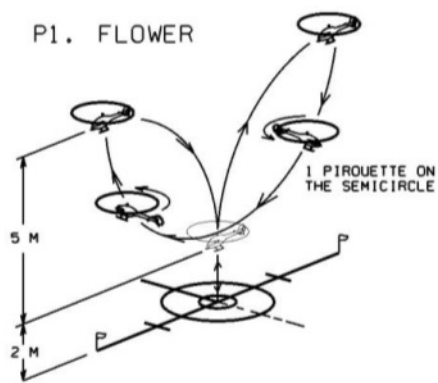

P3. DOUBLE CANDLE WITH DESCENDING FLIP

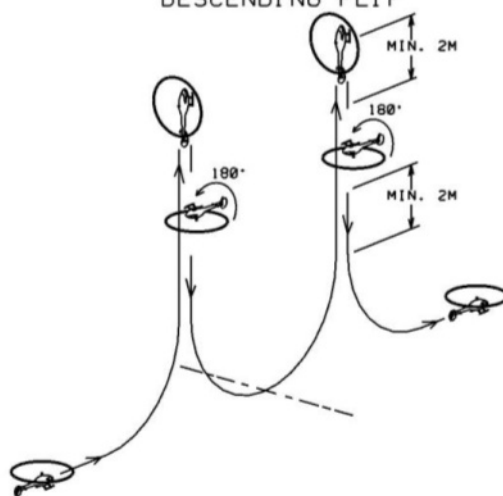

P4. PULLBACK WITH 3 HALF LOOPS

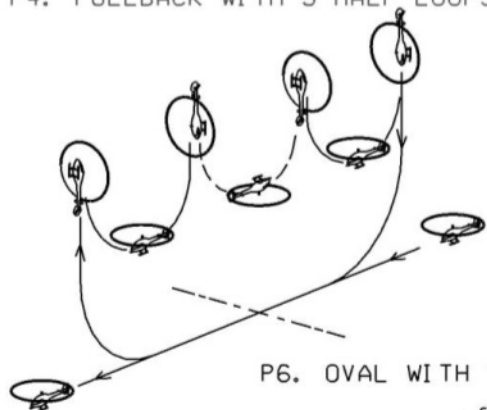

P5. UX

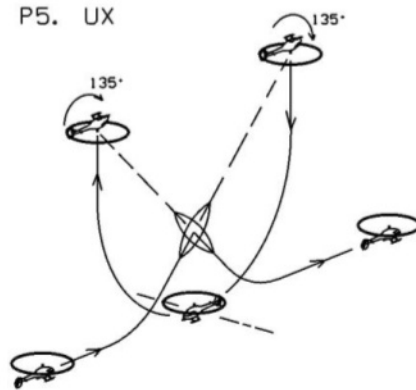

P6. OVAL WITH TRAVELLING FLIP

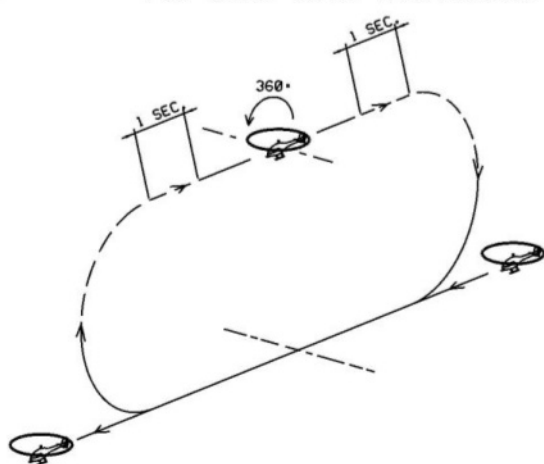

P7. OPPOSITE HALF AND FULL INVERTED ROLLS

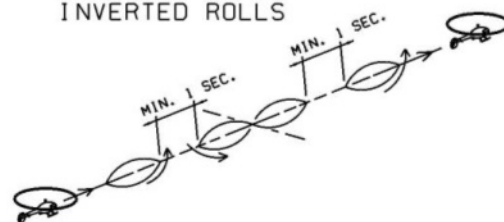

P8. LOOP WITH FLIP

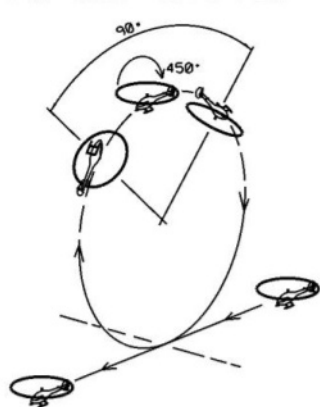

P9. AUTOROTATION WITH LOOP



図 5 D - F F 3 C スケジュール・F

F1. UMBRELLA



F2. FIR-TREE

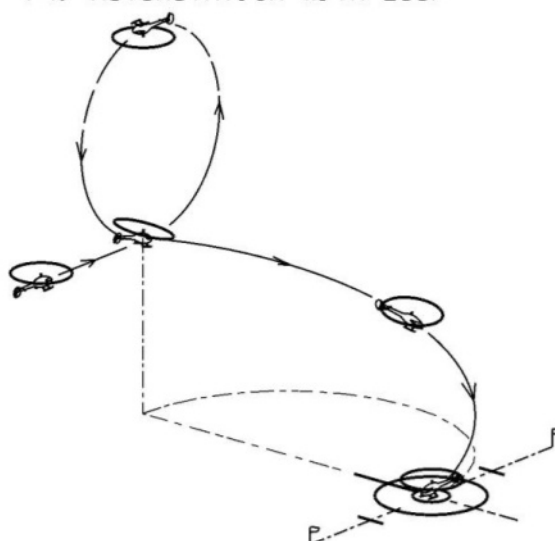
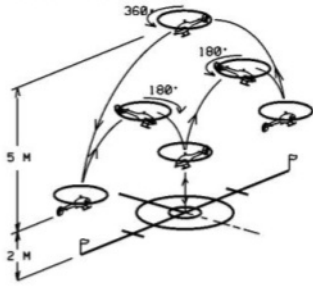
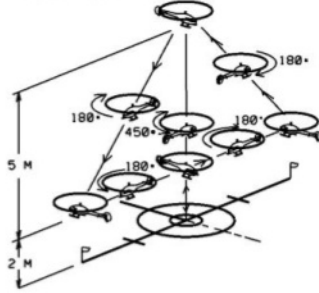

F3. CUBAN-EIGHT WITH 360°-FLIPS

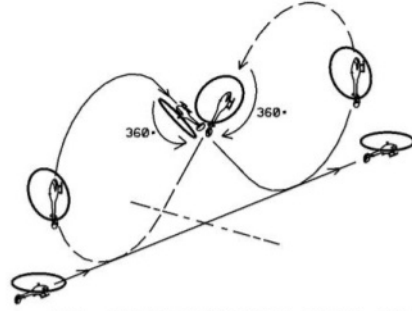

F4. OVAL WITH FLIPS AND 4-POINT-ROLL

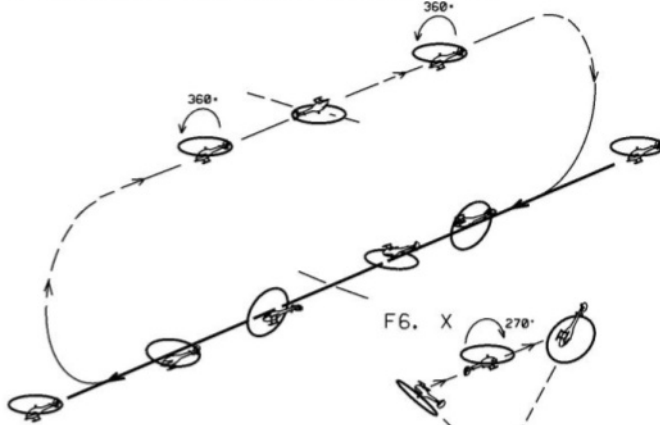

F5. DOUBLE CANDLE WITH HALF ROLLS AND DESCENDING FLIPS

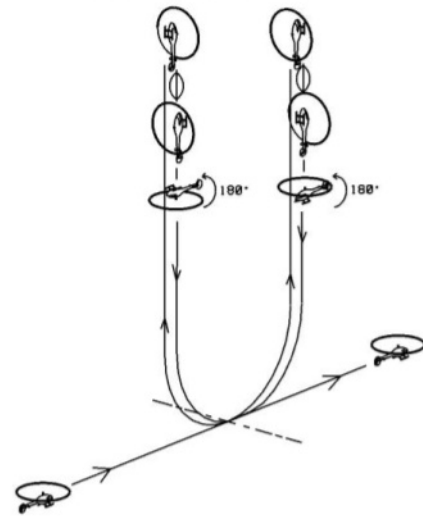

F6. X

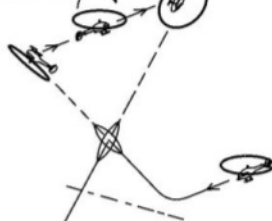

F7. STANDING EIGHT WITH HALF ROLLS

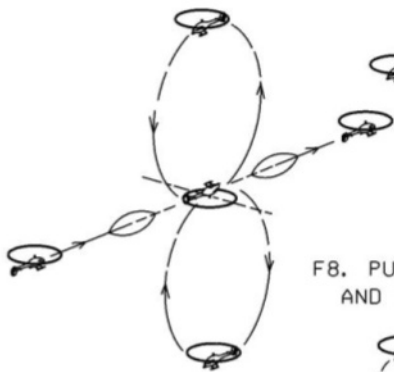

F9. AUTOROTATION WITH FLIPS AND PIRQUETTE

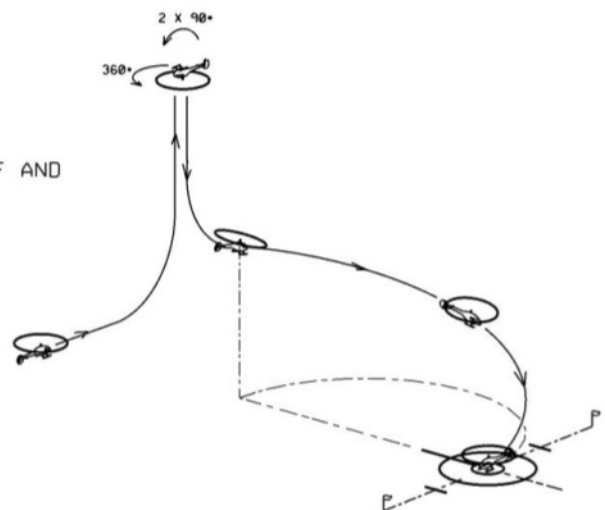

F8. PULLBACK WITH 2 HALF AND AND 1.5 LOOPS

